

GALLEY POWER

Digital Battery Power

USER'S MANUAL

GPC SERIES LOW VOLTAGE DISCONNECT

Galley Power LLC

www.galleypower.com

Table of Contents

Safety Notice.....	3
Disclaimer.....	3
Safety Instructions.....	4
1.Introduction.....	5
1.1 Features and Functions.....	5
1.2 GPC Low Voltage Disconnect Model Numbering.....	6
2.Installation.....	7
3.LED Indicators.....	9
3.1 GREEN LED.....	9
3.2 RED LED.....	10
4.Theory of Operation.....	11
4.1 Normal Operation.....	11
4.2 ON/OFF Switch Selection.....	11
4.3 Fault and Protection.....	12
4.4 Remote Control and Alarm (Optional).....	12
5.Specifications.....	14
5.1 Specifications.....	14
5.2 Default Disconnect Configuration.....	15
5.2 Mechanical Information.....	16
5.3 Wiring Diagram.....	17
LIMITED WARRANTY.....	18

About Galley Power LLC

Galley Power LLC is dedicated to provide cost-effective high performance battery management solutions. With extensive expertise on power electronics, batteries and renewable energy, Galley Power provides both standard and customized solutions with minimum time-to-market and maximum customer satisfaction.

Revision F, Sep 2016

Safety Notice

Galley Power LLC products are not designed, authorized, or warranted to be suitable for use in life support devices or systems or other critical applications. Certain applications may involve potential risks of death, personal injury, or severe property or environmental damage. Inclusion of Galley Power LLC products in such applications is understood to be fully at the customer's risk. The customer must provide all necessary design and operating safeguards to minimize inherent procedural hazards in order to minimize risks associated with the customer's applications.

Disclaimer

Galley Power LLC assumes no liability for customer product design or applications assistance.

Galley Power LLC does not warrant or represent that any license, either express or implied, is granted under any patent right, mask work right, copyright, or other intellectual property right of Galley Power LLC covering or relating to any combination, machine, or process in which such products or services might be or are used.

Galley Power LLC's publication of information regarding any third party's products or services does not constitute Galley Power LLC's approval, warranty, or endorsement thereof.

The information in this document is subject to change without notice.

Safety Instructions

This manual contains important instructions that should be followed during installation and maintenance of GalleyPower LLC's GPC series Low Voltage Disconnect Switch.

Consult your battery charging specifications to ensure that the GPC series Low Voltage Disconnect Switch is compatible with your chosen batteries. Please follow all the applicable safety regulatory requirements.

WARNING Be very careful when working with batteries. Lead-acid batteries can generate explosive gases, and short-circuit can draw thousands of amps from the battery. Read all instructions provided from the battery manufacturer.

WARNING Do not disconnect while the circuit is alive unless the area is known to be non-hazardous.

Voltage Rating Do not exceed the voltage ratings of the module. The output voltage of the charger must match the voltage rating of the battery.

Airflow Ensure adequate ventilation and space for air flow around the module.

Connection Copper wire with minimum 90°C insulation rating and between 12 AWG and 14 AWG gauge is recommended. Consult system requirements for wiring and connector selection.

Grounding Grounding is not required for operation. Grounding shall comply with the system requirements; GFDI devices and ground fault protection should be implemented at system level when necessary. Do not use positive grounding.

1. Introduction

Galley Power's GPC series Low Voltage Disconnect Switch (LVD) is a microcontroller-based solid-state low voltage disconnect load switch. The LVD prevents battery from over-discharge by disconnecting the attached load if the battery voltage drops below a pre-defined level; it reconnects when the battery is recharged.

1.1 Features and Functions

GPC series LVD module has following standard features:

- Ultra-low pass-through impedance 4.5mOhm.
- Ultra-low standby current consumption.
- Automatic 12V/24V detection: Upon power up, the LVD automatically detects battery voltage (i.e. 12 or 24V) and configure threshold value for either 12V system or 24V system accordingly.
- Ten pre-programmed options: With the rotary switch, the user can choose eight disconnect thresholds from 9.3V to 12.1V, in addition to a full-on and a full-off setting.
- Two rotary switch options: flushed option for easier user access and recessed option for enhanced access protection
- Continuous current up to 20A
- Red-Green dual color LED display for battery monitoring and fault reporting.
- Low operation current:
 - In 12V operation, less than 0.3mA in disconnect mode and less than 4mA during normal operation.
 - In 24V operation, less than 0.7mA in disconnect mode and less than 6mA during normal operation.
- Solid-state switch with low noise and interference
- Comprehensive protections including input over-voltage, input under-voltage, over-temperature, reverse polarity (with inline fuse) and over-load detection.
- Three cables for input (battery), output (load) and ground connections.
- One-year limited warranty

GPC series LVD module has following optional features:

- Alarm output (85mA sinking capability)
- Relay driver (1A sinking capability)
- Remote ON input: User can force the LVD on.
- Remote OFF input: user can force the LVD off.
- External temperature sensor support and disconnect voltage temperature compensation.
- Potted version.

1.2 GPC Low Voltage Disconnect Model Numbering

GPC LVD units are provided in two current rating with choice of control options.

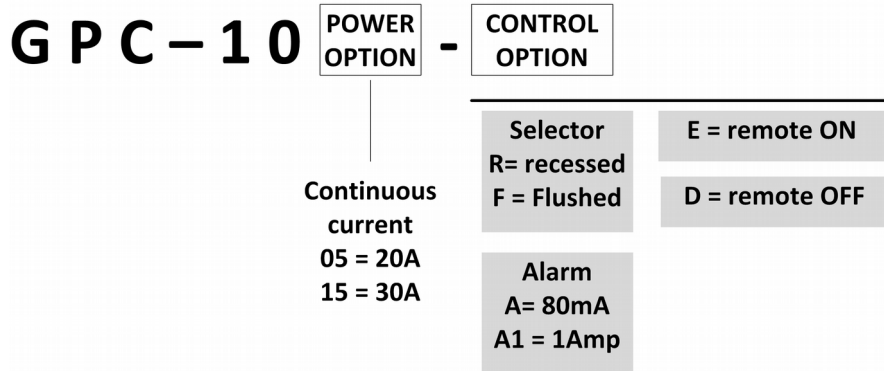

GPC-1005-R	20A continuous current with recessed selector
GPC-1015-FA	30A continuous current with 80mA alarm output and flushed selector
GPC-1005-REDA1	20A continuous current with remote ON/OFF control and 1A alarm output

2. Installation

GPC series LVD module are easy to install and operate.

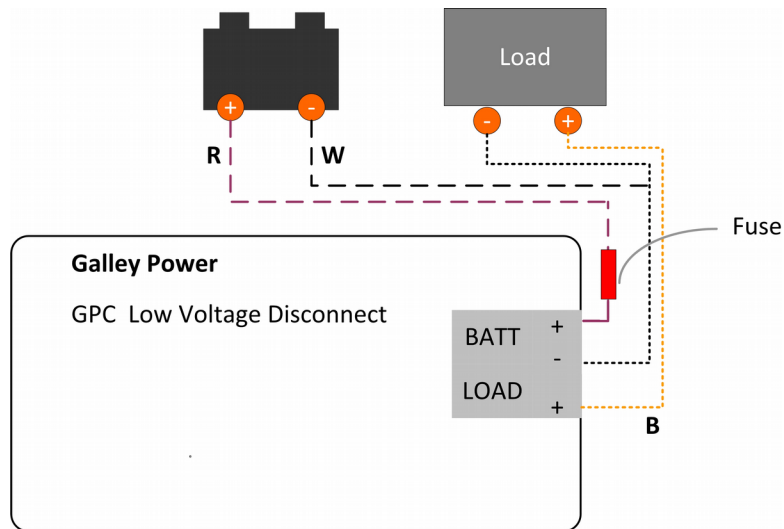

Fig. 1 Basic LVD module wiring diagram

Step 1: Choose and Install in-line fuse

Choose in-line fuse based on the load rating. Install the fuse in series with the input (battery+) wire.

NOTES:

- ◆ In-line fuse shall be used for safe operation.
- ◆ The in-line fuse is necessary for reverse polarity protection

Step 2: MOUNTING the LVD module

Choose a suitable location to mount the LVD. Optionally, the disconnect option can be selected before mounting the module.

NOTES:

- ◆ It is recommended that the LVD be installed close to the battery.
- ◆ For optimal performance, do not use the LVD in a location exposed to direct sunlight.
- ◆ Use appropriate hardware to mount the device.

Step 3: Connect the LVD controller to the battery positive terminal.

Connect the RED wire from the LVD to the battery positive terminal through the in-line fuse.

Step 4: Connect the load to the LVD and battery negative terminal

Connect the BLACK wire from the LVD to the load positive terminal

Step 5: Wire the control wires when available

Certain LVD modules support alarm output, remote on, and remote off. Please wire them following Section 5.3 Wiring Diagram.

Step 6: Connecting the LVD controller to the battery negative terminal

Connect the WHITE wire from the LVD to the battery negative terminal. After the connection, the LVD starts up. The green LED will turn on for 6 seconds detecting battery type and go into normal operation afterwards.

Step 7: (Optional) Select the cut-off voltage for the load

GPC series LVD module offers programmable disconnect voltage settings through a rotary switch.

- "0" setting indicates "off" position. Selecting "0" puts LVD in the permanent disconnect state.
- "1" setting indicates "on" position. Selecting "1" puts LVD in the permanent connected state.
- "2" to "9" sets different disconnect configurations. Please refer to section ***Default Disconnection Configuration*** for details.

3. LED Indicators

GPC series LVD module has dual-color (RED and GREEN) LED outputs for status indication.

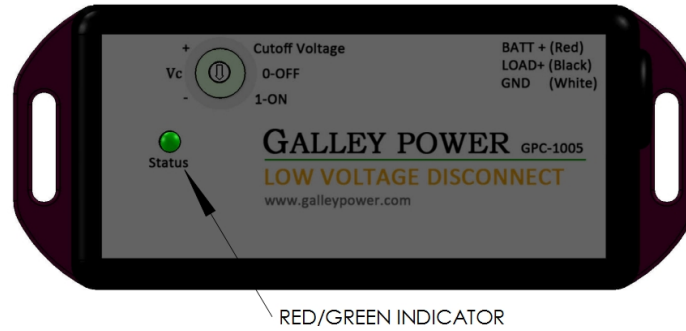

Fig. 2 LVD module LED display

3.1 GREEN LED

The green LED indicator will light when the LVD is on. The LED blinking pattern indicates the battery voltage as an indicator for battery state-of-charge. As an exception, during power up, the green LED will be solid on with the LVD switch being off.

GREEN LED Indicator	Description	Battery voltage
	Two long blinks	$>V_{Full}$
	A long followed by a short blink	$V_{Full} > V_{Batt} \geq V_{Reconnect}$
	Two short blinks	$V_{Reconnect} > V_{Batt} > V_{Disconnect}$
	One short blink	$V_{Batt} \leq V_{Disconnect}$
	Solid on	LVD starts up

Table 1. Green LED

NOTE:

1. The default V_{Full} is 14V.

3.2 RED LED

RED LED indicates a LVD fault condition. If the fault condition is cleared, the charger will automatically recovers and the red LED turns off. Only one fault condition displays when multiple faults are pending.

RED LED blink patterns indicate the fault source.







RED LED Indicator	Description	Error Status
	One short red blink every 2 second	LVD in disconnect mode
	Two long blinks every 3 second	Battery voltage too high
	Two short red blinks every 3 second	Battery voltage too low
	Continuous fast red blinking	Output fault/over-load
	One long red blink every 3 second	Over-temperature protection
	Solid	System error (Contact Galley Power LLC)

Table 2. Red LED

NOTE:

- ◆ Usually the battery has been in into disconnect mode before triggering input under-voltage fault. If the under-voltage fault triggered due to other reasons and it lasts for more than 5 minutes (when the disconnect delay is over 5 minutes), the display will fall back into disconnect mode (one short blink)

4. Theory of Operation

4.1 Normal Operation

Upon power up, the LVD module automatically detects the 12V and 24V type battery by measuring the input voltage. If the input voltage is less than 19V, the LDV goes into 12V mode; otherwise, it is configured in 24V mode.

When there is no fault pending, the LVD will turn on the load switch and power the load. The Green LED will report the input battery voltage as an indicator of battery state-of-charge.

The LVD continuously monitoring the input voltage; it turns off the load switch if the input battery voltage is less than the disconnect voltage for more than the disconnect delay. The LVD will turn the load switch back on if the input battery voltage is higher than the reconnect voltage for more than the reconnect delay. The voltage threshold and delay time can be chosen by the rotary switch or be customized.

If the LVD is off for more than 5 minutes, the unit will go into Disconnect mode; in Disconnect mode, the unit will drain 0.26mA type for 12V battery and 0.6mA for 24V system.

The LVD will turn off the load switch if there is a fault condition. The LVD will stay off until the fault condition is cleared. Please refer to section on protection for details.

4.2 ON/OFF Switch Selection

The rotary switch has an ON selection and OFF selection.

When ON is selected, the LVD is forced on if there is no fault pending. This ON position also clears/resets the internal disconnection timer. If the rotary switch is turned to another option, the LVD will stay on, and the disconnection monitoring restarted.

When OFF is selected, the LVD is forced off. This OFF position also clears/resets the internal reconnect

timer. If the rotary switch is turned to another option, the LVD will stay off, and the reconnect monitoring restarted.

The ON/OFF selection is different from the optional remote ON/OFF command. The optional remote ON/OFF command will forced the LVD on/off but the LVD will resume its previous state when the remote command is removed.

4.3 Fault and Protection

The module has comprehensive protections for input over-voltage, input under-voltage, over-temperature and over-load detection.

The LVD will goes into input overvoltage protection if the input voltage is higher than 16V in 12V and over 32V in 24V mode. The typical reaction delay is 1 second to prevent false positive due to noise. The LVD will resume operation 2 second after the input voltage is cleared.

The LVD will goes into input under-voltage protection if the input voltage falls under 8V. This will protect both the LVD and load if the battery input has serious fault.

The LVD goes into over-temperature protection and turn off the load switch if the internal temperature reaches 85C. It resumes operation after the temperature falls under 55C.

The external in-line fuse at the input is mandatory for safe operation. The LVD also has load monitoring functions. The load switch has very low pass-through resistance, and the drop off voltage is well under 100mV under rated current. The LVD will measure the drop off voltage, and it goes into protection of the drop off voltage is higher than 0.4V for 5 second and higher than 0.8V for 0.15second. The LVD will re-start after 60 seconds. This monitoring function is useful for overload detection, load switch self-monitoring and load monitoring.

4.4 Remote Control and Alarm (Optional)

The LVD has optional ON/OFF input and two alarm outputs.

The remote ON input is active low signal. When pulled to ground, the remote ON input is active and

force the LVD on if there is not fault pending. After the ON command is removed, the LVD will resume its previous state. The remote ON input override the rotary switch selection.

The remote OFF input is active low signal. When pulled to ground, the remote OFF input is active and force the LVD off. After the OFF command is removed, the LVD will resume its previous state. The remote OFF input override the rotary switch selection.

The recommended input range of remote ON/OFF signal is 0~33V. When both remote ON and remote OFF signals are active, both signals will be ignored.

There are two alarm output options, and they are open drain signal and active low. Please note that, when alarm device is used, the alarm device will drain current from the battery when active.

One alarm output is capable of sinking 85mA max for driving small devices such as a buzzer or a LED light. The second optional alarm output is capable of sinking 1A max. Both output has voltage range of 0~35V with maximum allowed 42V. Please take precaution for peak voltage protection if an inductive load is used with either a freewheeling diode in parallel with the alarm device or a TVS between alarm output and ground.

5. Specifications

GPC series Low Voltage Disconnect Switch has following standard specifications to cover most common usages. Configurable versions are also available so the user can customize following parameters to meet unique application needs.

5.1 Specifications

Parameters	GPC-1005	GPC-1015
Maximum Continuous Load Current	20A	30A
Peak Current	80A	120A
Operating voltage	8~35VDC Auto detect 12V: 8-19 VDC Auto detect 24V: 20-35 VDC	
Current Consumption, switch ON (typical)	12V mode: 3.5mA 24V mode: 5.8mA	
Current Consumption, disconnect (typical)	12V mode: 0.26mA 24V mode: 0.65mA	
Overvoltage Shutdown (typical)	12V mode: 16V 24V mode: 32V	
Voltage drop (typical)	45mV@10A	22mV@10A
Dimensions (LxWxH)	80x40x20mm	
Weight	5oz (non-potted)	
Operating temperature	-40 ~ 55 °C	

5.2 Default Disconnect Configuration

12V Mode Disconnect Configuration

Switch Location	Disconnect voltage(V)	Reconnect voltage(V)	Disconnect delay (Sec.)	Reconnect delay (Sec.)	Warning voltage (V)
2	9.3	10.8	3	6	9.5
3	9.7	11.2	3	6	9.9
4	10.1	11.6	5	6	10.3
5	10.5	12	5	6	10.7
6	10.9	12.4	10	6	11.1
7	11.3	12.8	10	6	11.5
8	11.7	13	15	6	11.9
9	12.1	13	90	6	12.3

NOTES:

1. Warning voltage is used when optional alarm output is available.
2. All parameters above are programmable.
3. When rotary switch location is at 1, the green LED will display based on voltage setting of location 5.

24V Mode Disconnect Configuration

Switch Location	Disconnect voltage(V)	Reconnect voltage(V)	Disconnect delay (Sec.)	Reconnect delay (Sec., typical)	Warning voltage (V)
2	18.6	21.6	3	6	19
3	19.4	22.4	3	6	19.8
4	20.2	23.2	5	6	20.6
5	21	24	5	6	21.4
6	21.8	24.8	10	6	22.2
7	22.6	25.6	10	6	23
8	23.4	26	15	6	23.8
9	24.2	26	90	6	24.6

NOTES:

1. Warning voltage is used when optional alarm output is available.
2. All parameters above are programmable.
3. When rotary switch location is at 1, the green LED will display based on voltage setting of location 5.

5.2 Mechanical Information

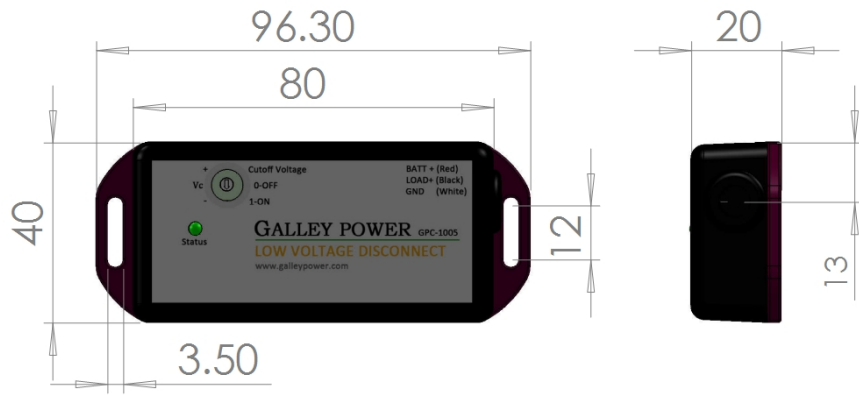

DIMENSIONS ARE IN MILLIMETERS

5.3 Wiring Diagram

Following diagram shows all power wires and control wires connection. Depending on the model number, some signals will not be available.

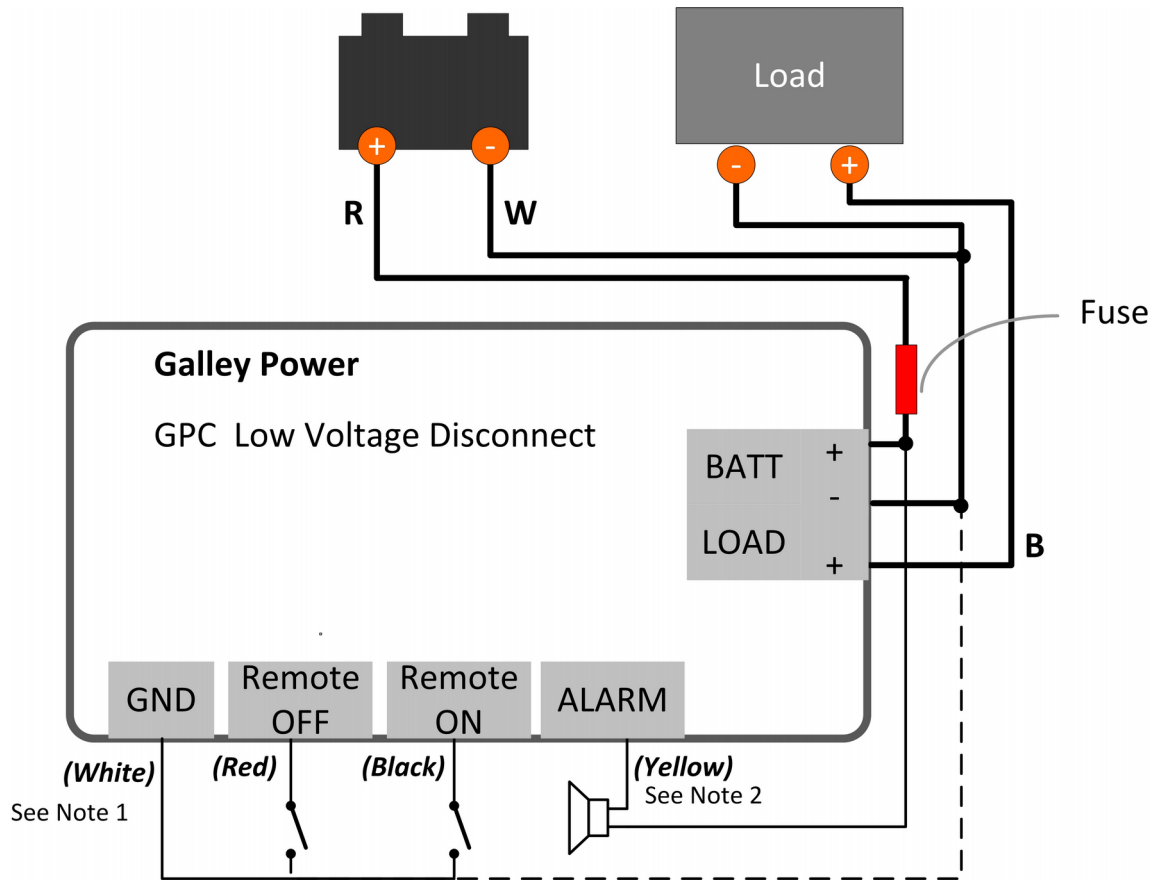

NOTES:

1. This GND wire is connected to GND(White) inside the LVD. It provides an easy ground access when wiring the remote on and remote off signals.
2. The max peak voltage allowed on ALARM output is 42V. When the alarm device is inductive, use either a TVS/Zener diode between the ALARM and ground to clamp the peak voltage or a free-wheeling diode in parallel with the alarm device.

LIMITED WARRANTY

Galley Power LLC warrants this GPC series LVD controller to be free from defects in material and workmanship for a period of One (1) years from the date of shipment to the original end user, and, at its option, repair or replace, free of charge, any such defective products. This limited warranty shall only apply if this product has been operated in accordance with the User's Manual. This limited warranty does not apply when this product is damaged by accident, negligence, abuse or improper use or is subjected to unauthorized product modification or attempted repair.

To obtain warranty service

For warranty service, please contact, with proof of purchase, Galley Power LLC at info@galleypower.com

For rapid disposition of your warranty claim, please include the model, serial number and detailed reason for the failure, the panel type/size, type of batteries, system loads and any other related information. Galley Power will cover the return shipping charges if the claims are covered by the warranty.

THE WARRANTY AND REMEDIES SET FORTH ABOVE ARE EXCLUSIVE AND IN LIEU OF ALL OTHERS, EXPRESS OR IMPLIED. GALLEY POWER LLC SPECIFICALLY DISCLAIMS ANY AND ALL IMPLIED WARRANTIES, INCLUDING, WITHOUT LIMITATION, WARRANTIES OF MERCHANTABILITY AND FITNESS FOR A PARTICULAR PURPOSE. No Galley Power LLC distributor, agent or employee is authorized to make any modification or extension to this warranty.

GALLEY POWER LLC IS NOT RESPONSIBLE FOR INCIDENTAL OR CONSEQUENTIAL DAMAGES OF ANY KIND, INCLUDING BUT NOT LIMITED TO LOST PROFITS, DOWNTIME, GOODWILL OR DAMAGE TO EQUIPMENT OR PROPERTY.

Phone: (978)558-0048

Fax: (978)763-1101

Email: info@galleypower.com

Website: www.galleypower.com